

# BACK MOUNT UNDERCOUNTER FREEZER BACK MOUNTED CONDENSING UNIT

Project Name: \_\_\_\_\_

Project Location: \_\_\_\_\_

Model #: \_\_\_\_\_ Quantity: \_\_\_\_\_

Available Warehouse: \_\_\_\_\_

**ETB Series**

**Model: ETBSF2**



## Refrigeration System

- Bottom mounted, self-contained and retractable condensing unit uses environmentally friendly R404A\* refrigerant with zero (0) Ozone Depletion Potential (ODP) and EPA compliant R290 refrigerant with zero (0) Ozone Depletion Potential (ODP) and three (3) Global Warming Potential (GWP). R290 condensing units are replaceable and require no on-site brazing. \*Ask about alternative refrigerant.
- Front air breathing for flexibility in installation.
- PSC evaporator fan motors for R404A models. Electronically commutated (ECM) fan motors for R290 models.
- R290 models include full-length air duct system.
- Time-initiated and temperature-terminated defrost cycle with defrost heater.
- Large capacity, corrosion-resistant condenser and evaporator coils.
- Self-maintaining, energy-efficient condensate drain pan requires no external drains or electric heaters.
- High performance condenser fan motors ensure efficient compressor ventilation. R290 models use auto-reverse condenser fan motors which also support condenser coil cleaning. Refer to owner's manual for full maintenance instructions.
- Pressure relief devices allow smooth access to cabinet interior when reopening doors.
- Pre-wired and ready to plug, 115V/60Hz/1Ph, NEMA 5-15P.

## Cabinet Construction

- Heavy duty stainless steel interior / exterior with rounded corners for a hazard-free workspace.
- Open spaced interior with no walls between compartments.
- 16 gauge, high quality stainless steel worktop.
- Galvanized steel bottom and rear.
- 2.5" thick high density polyurethane insulation.
- Four 5" swivel casters with locks on front set.

## Doors

- Heavy duty stainless steel interior / exterior.
- 2.5" thick high density polyurethane insulation.
- Frame heaters prevent exterior moisture build up.
- Self-closing with adjustable torsion system for a positive seal.
- Snap-in magnetic door gasket make cleaning and replacement an easy process.
- High strength, recessed door handles.
- Pre-installed door locks keep your items safe from theft.

## Shelving

- Two epoxy coated, steel wire shelves per section.
- Height adjustable stainless steel clips.

## Temperature Control

- Multi-function digital controller with easy to read LED display.
- Factory preset temperature, -4°F. Temperature setting range from -10°F to 54°F.
- R290 models include audible overheat protection alarm for compressor and condenser coil.

## Options

- 4" high stainless steel backsplash for worktop application.
- Additional shelving.
- 3" swivel casters with locks.
- 3.5" – 6" height-adjustable and interchangeable legs.
- NSF Certified Stainless Steel Double Overshelf.



Please visit our website for updated Energy Efficiency information

Ref/ Frz/Dual	Doors	Capacity Cu. Ft.	Shelves	Refrigerant	HP	Power V-Hz-Ph	Amps	Crated Weight	Exterior Dimensions		
									L	D	H*
FRZ	2	10	4	R-290	1/3	115-60-1	4.7	231 lbs (105kg)	35.625" (905mm)	31.5" (800mm)	30.25" (768mm)

(†)Based on evaporating temperature of 23°F (-5°C) & condensing temperature of 131°F (55°C). (►) Product capacity is calculated based on standard industry figures. (✳) Reference plan view for clarification on caster/unit height. If dimensions and capacity are critical, please contact Everest Refrigeration. Blizzard R290 replacement is at the sole discretion of Everest Refrigeration. Specifications subject to change without notice.

# BACK MOUNT UNDERCOUNTER FREEZER

## BACK MOUNTED CONDENSING UNIT

**ETB Series Model: ETBSF2**

### DIMENSIONAL DATA

External Dimensions	L	35.625" (905mm)
	D	31.5" (800mm)
	H*	30.25" (768mm)
Crated Weight	231 lbs. (105kg)	
Doors/Drawers/Lids	2	
Max Weight Support (LBS)	-	

### STORAGE DATA

Net Capacity Cu. Ft. ▶	10
Shelves	4
Barrels	-
20 oz. Bottles	-
12 oz. Bottles	-
12 oz. Cans	-
8" Mugs	-
# of Pans (Top)	-
# of Pans (Drawer)	-
Dividers	-
Trays	-

### ELECTRICAL DATA

Voltage	115-60-1
Full Load Amperage	4.7A
Feed Wires with Ground	3
Cord Length	9ft
NEMA Plug Type	 NEMA 5-15P

### REFRIGERATION DATA

Compressor Mounting	Back
Refrigerant	R-290
Compressor HP	1/3
BTU/HR †	1360

### KEY

D	Door	R	Refrigerator
L	Lid	REF	Refrigerator
H	Half Door	F	Freezer
FD	Full Door	FRZ	Freezer
SD	Solid Door	DUAL	REF/FRZ Combo
GD	Glass Door	DR	Drawer

	Elevation	Right	Plan	3D	Back

### PLAN VIEW

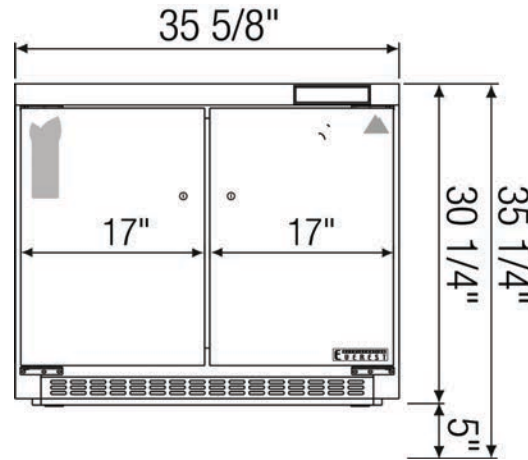

**FRONT**

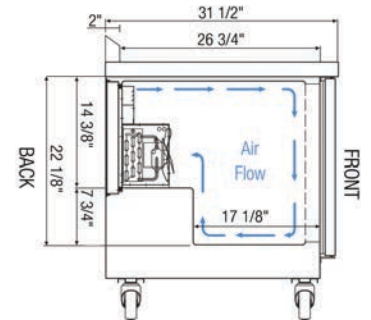

**SIDE**

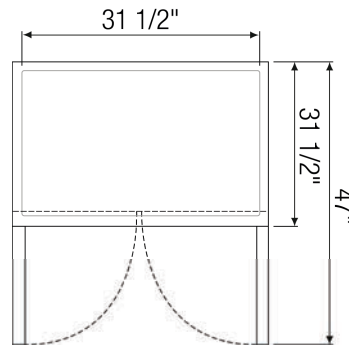

**TOP**

### ACCESSORIES & OPTIONS

Part Number	Description
<b>Additional Shelving</b>	Contact Everest Refrigeration for more information.
<b>AJL03-00</b>	Interchangeable Leg for Caster (Optional)
<b>BKSPL01-00</b>	4" High (35-1/2" Long) Stainless Steel Backsplash
<b>CASA3-01</b>	3" Overall Height Caster Assembly - (2) Front (2) Rear
<b>OS21-00</b>	Double overshelf (35" L x 13.5" D x 48" H). Adds 31" of height to unit.

(†) Based on evaporating temperature of 23°F (-5°C) & condensing temperature of 131°F (55°C). (▶) Product capacity is calculated based on standard industry figures. (✳) Reference plan view for clarification on caster/unit height. If dimensions and capacity are critical, please contact Everest Refrigeration. Blizzard R290 replacement is at the sole discretion of Everest Refrigeration. Specifications subject to change without notice.